

FLATWORK ≠ CURB & GUTTER



FORM DIVISION



METAL FORMS CORPORATION
SINCE 1909

Form To Finish Technology™

SPECIFICATIONS

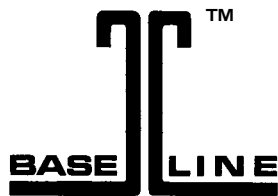

HEAVY-DUTY FORMS

STANDARD 10' LENGTHS

HEIGHT OF FORM	TWO (2) POCKETS	THREE (3) POCKETS
4"	56 LBS.	
5"	62 LBS.	THIRD POCKET
6"	68 LBS.	NORMALLY NOT
7"	74 LBS.	REQUIRED ON
8"	80 LBS.	FORMS UNDER
9"	86 LBS.	
10"	91 LBS.	12" HIGH
11"	96 LBS.	
12"		109 LBS.

13" to 24" CONTACT FACTORY

Standard BASE-LINE Heavy-Duty (10 ga.) Forms are supplied with: 4" base and 2" top tread; 3/16" full-height fixed end connections; 3/8" bar stock wedges; 10 ga. box-type stake pockets.



LIGHTWEIGHT FORMS

STANDARD 10' LENGTHS

HEIGHT OF FORM	TWO (2) POCKETS	THREE (3) POCKETS
4"	37 LBS.	39 LBS.
5"	42 LBS.	44 LBS.
6"	47 LBS.	50 LBS.
7"	51 LBS.	54 LBS.
8"	55 LBS.	58 LBS.
9"		63 LBS.
10"		67 LBS.
11"		75 LBS.
12"		80 LBS.

13" & 14" CONTACT FACTORY

Standard SLIM-LINE Lightweight (12 ga.) Forms are supplied with: 2" base and 2" top tread; 10 ga. end connections; 3/8" bar stock wedges; 10 ga. V-type stake pockets.

NAIL STAKES

The ideal accessory for wood forming. Round nail stakes can also be used as form stakes.



ACCESSORIES

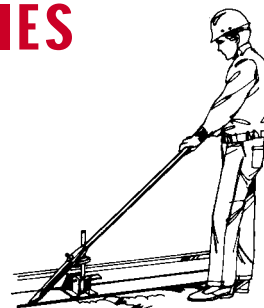

FORM STAKES

Solid 3/4", 7/8" and 1" dia. steel stakes available in any length



FORM DIVISION



STAKE DIVISION



METAL FORMS CORPORATION
SINCE 1909



PLASTIC DIVISION



EQUIPMENT DIVISION

3334 NORTH BOOTH STREET, MILWAUKEE, WISCONSIN 53212 U.S.A. • TEL: 414 • 964 • 4550 FAX: 414 • 964 • 4503

CURB & GUTTER FORMS

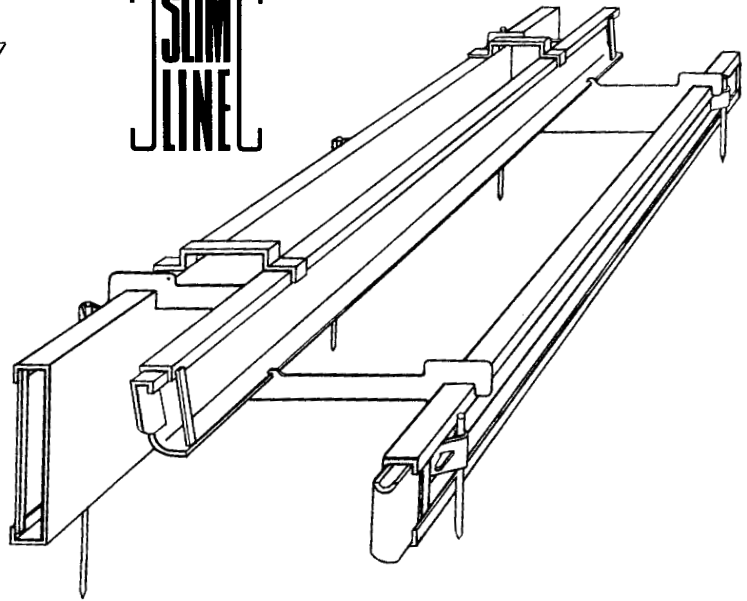
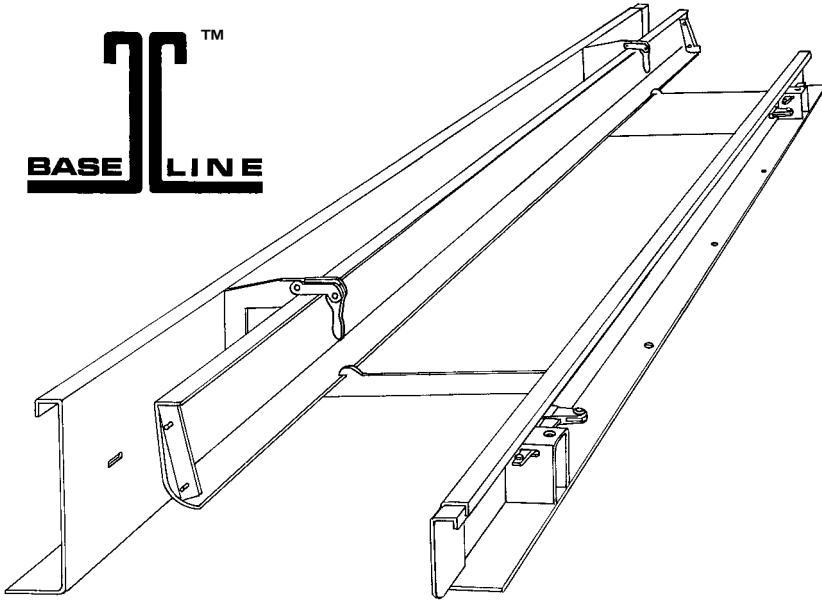
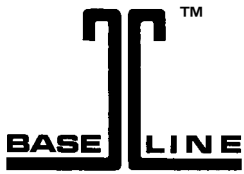

HEAVY-DUTY

10 ga. SPECIAL ANALYSIS STEEL

Heavy-duty design assures rugged performance and long life

4" WIDE

Provides added support and stability while facilitating easy clean-up

BOX TYPE

Full-height pockets completely reinforce the form and maintain the face 90° to the base

CLAMP TYPE

Clamps securely lock all forms into a solid, stationary unit

MATERIAL

BASE

STAKE POCKETS

DIVISION PLATES

12ga. SPECIAL ANALYSIS STEEL

Streamlined design permits easy handling and efficient transport

2" WIDE

Permits minimum clearance pours and allows forms to be reversed

V-TYPE

Single pockets and double pockets (on forms 9" to 12" high) securely lock form to either 3/4" or 7/8" dia. stakes

SLIP-ON TYPE

Division plates drop over front and back forms at any location

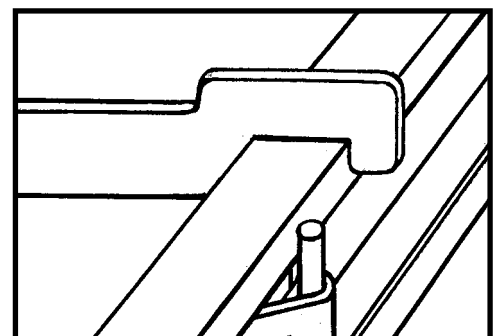
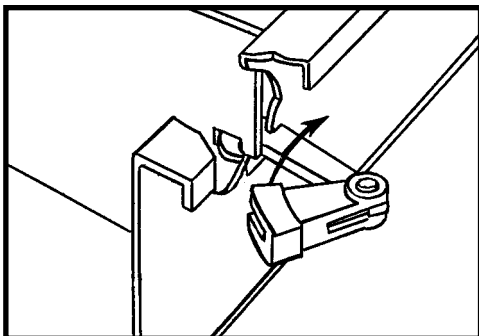

FLATWORK FORMS

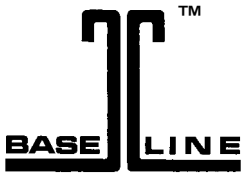

HEAVY-DUTY



LIGHTWEIGHT

12 GAUGE STEEL

Streamlined design permits easy handling and efficient transport.

BOX-TYPE STAKE POCKETS

Maximum support provided by pockets that attach to both the base and the face and extend to the base/face corner.

10 GAUGE STEEL

Heavy-duty design assures rugged performance and long life.

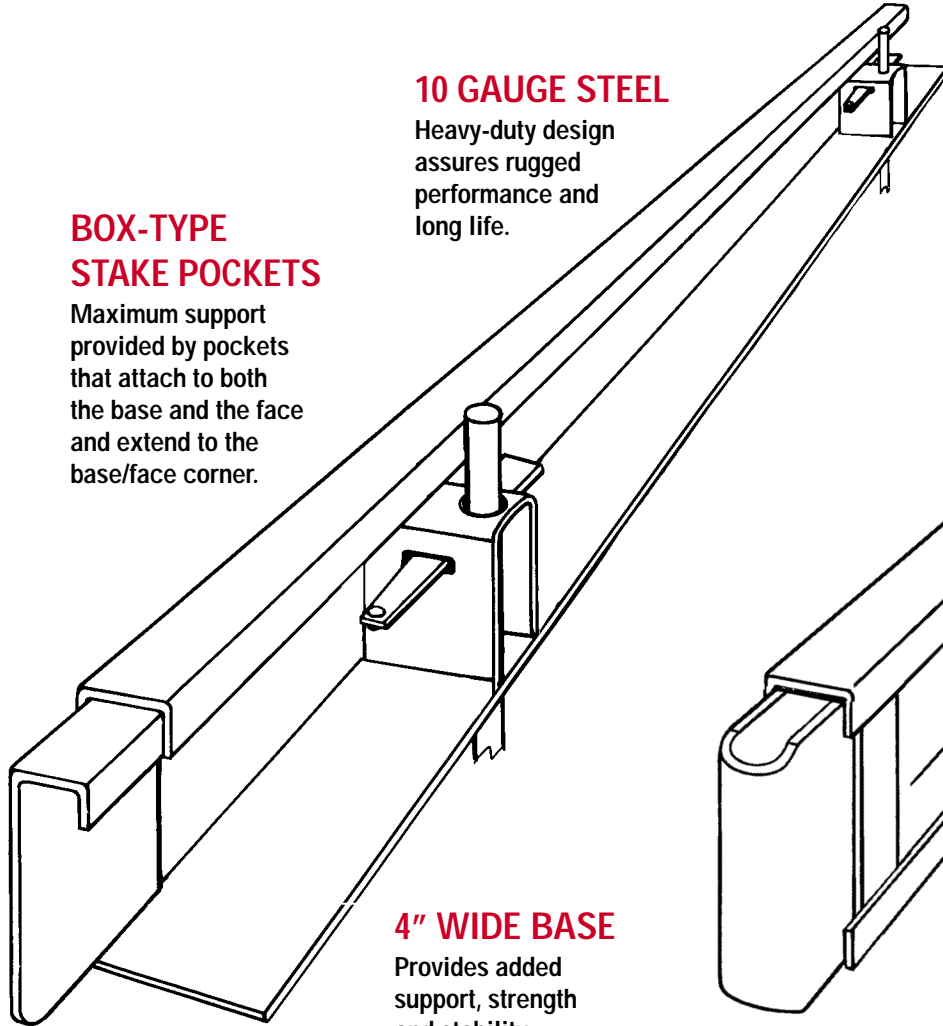

4" WIDE BASE

Provides added support, strength and stability.

FULL-HEIGHT END CONNECTION

Provides full-depth alignment and a sturdy, reinforced joint.

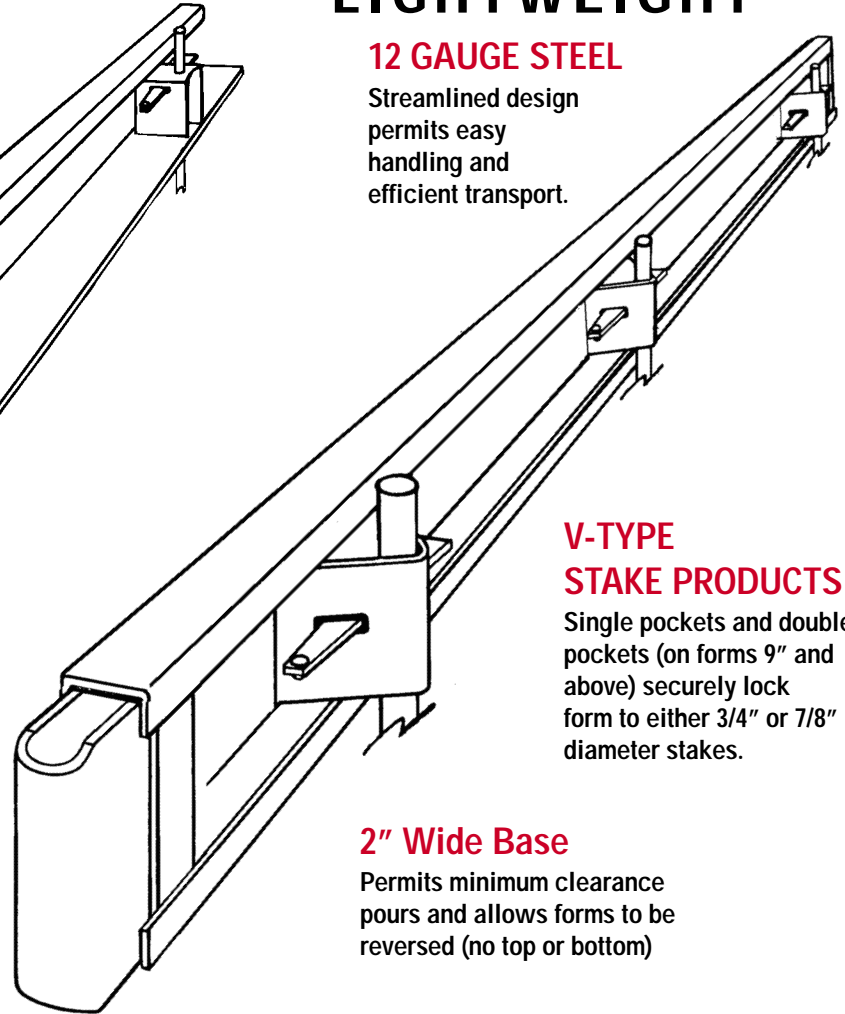

V-TYPE STAKE PRODUCTS

Single pockets and double pockets (on forms 9" and above) securely lock form to either 3/4" or 7/8" diameter stakes.

2" Wide Base

Permits minimum clearance pours and allows forms to be reversed (no top or bottom)

BULLNOSE END CONNECTION

Provides self-aligning, tight joint.



FLEXIBLE RADIUS

Provides a convenient method of forming all types of curved and radius work.

SPECIAL PUNCHING SLIDING END CONNECTION

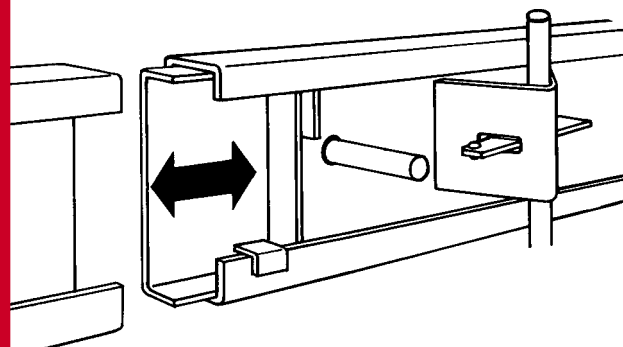

Hole punching can be specified in the face, base or top tread.

Sliding end connections permit forms to be stripped over dowel bars.