

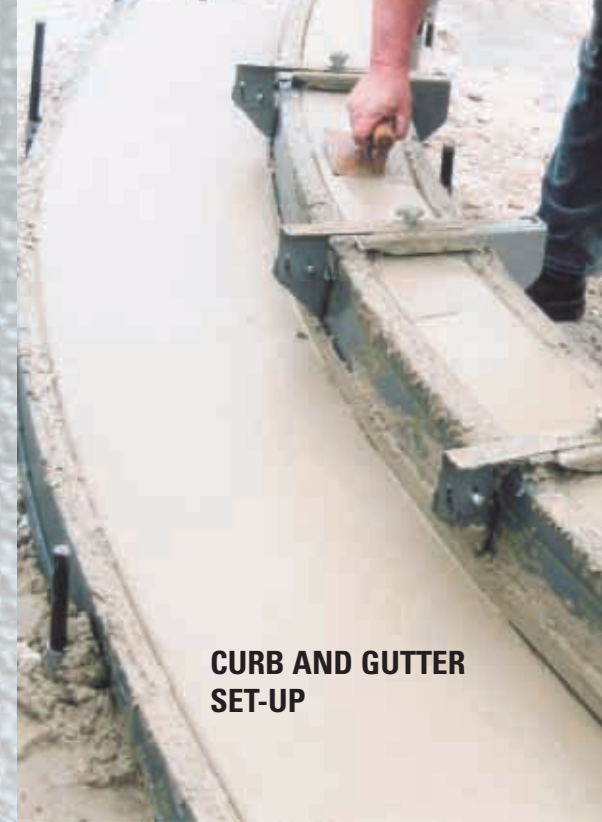

**STACKING POCKETS
OVERHEAD HANGER UNITS**

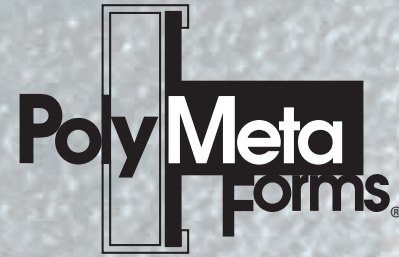

**CURB AND GUTTER
SET-UP**



Video available upon request

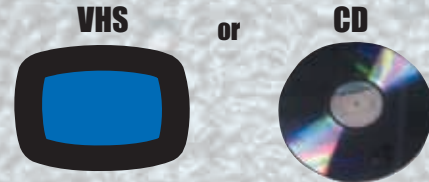

A REVOLUTIONARY CONCRETE FORMING SYSTEM

PATENT PENDING

PolyMeta Forms®

An Engineered System Combining
The Lightweight Advantage of Plastic
With The Strength of Steel.

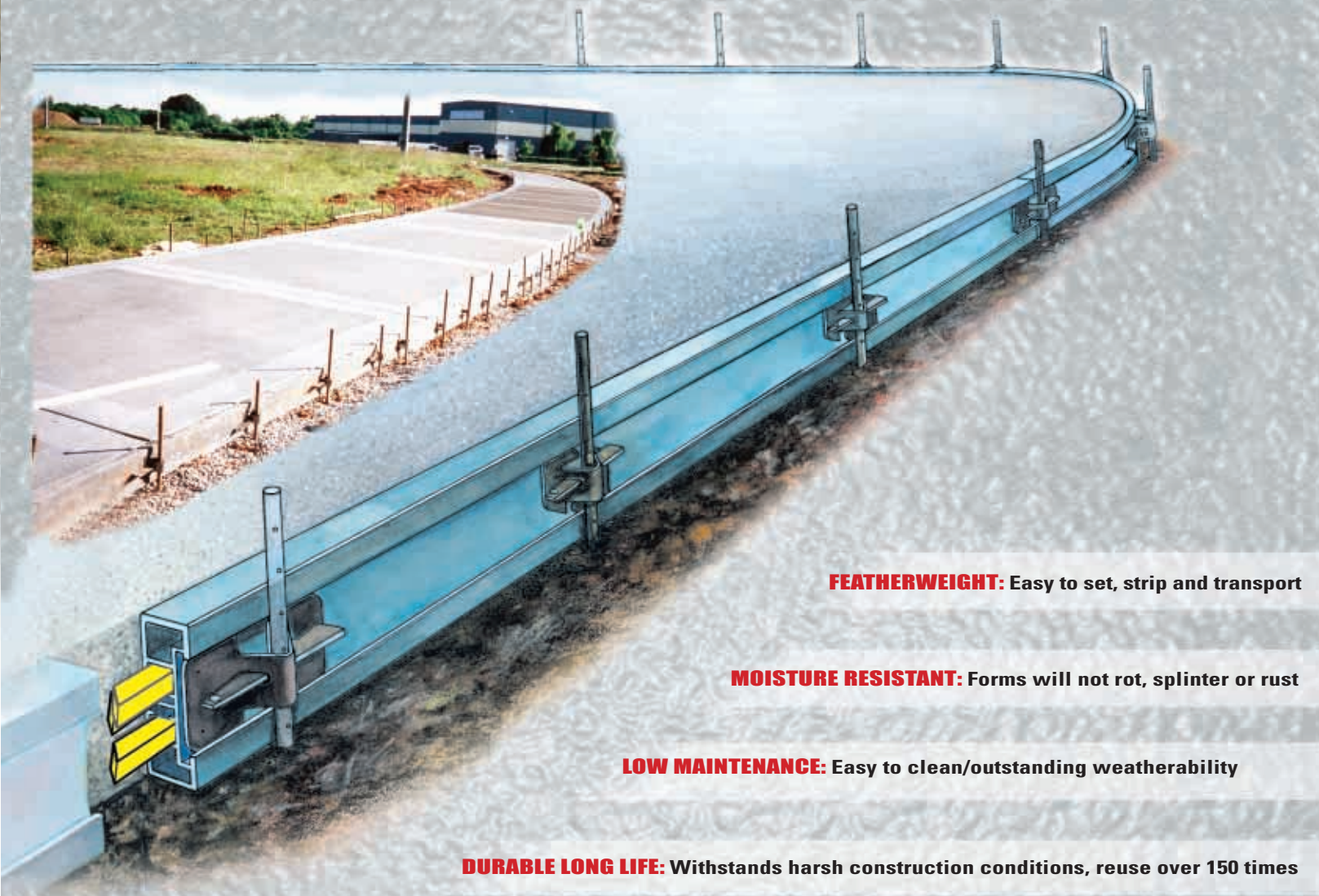

FEATHERWEIGHT: Easy to set, strip and transport

MOISTURE RESISTANT: Forms will not rot, splinter or rust

LOW MAINTENANCE: Easy to clean/outstanding weatherability

DURABLE LONG LIFE: Withstands harsh construction conditions, reuse over 150 times

VERSATILE: Straight and radius forming systems designed for both flatwork and curb & gutter construction

PRODUCTS

POLY FORMS

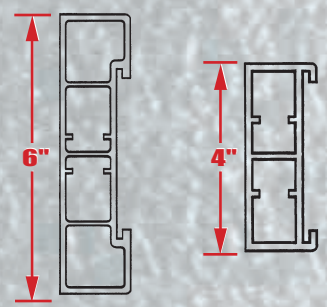

SPECIFICATIONS

MATERIAL:	High density Polyethylene (HDPE)
HEIGHT:	4" and 6"
LENGTH:	12'
WEIGHT:	4" Flexible 0.5 lbs. per foot
	4" Straight 1.0 lbs. per foot
	6" Flexible 0.75 lbs. per foot
	6" Straight 1.25 lbs. per foot

SHIPPING

12 ft BOX
10 FORMS PER BOX
4" Flexible 77 lbs. per box
4" Straight 129 lbs. per box
6" Flexible 105 lbs. per box
6" Straight 155 lbs. per box

META STAKE POCKETS

MATERIAL:	Special Analysis Steel
WEIGHT:	Slide 1.3 lbs. per pocket
	Twist 1.3 lbs. per pocket
	Stacking 3.0 lbs. per pocket

RECOMMENDED QUANTITIES
4" & 6" Forms/Straight & Flexible

Per 12' length:	4 Pockets
	1-Slide Pocket
	3-Twist Pockets
Per Box:	2 Buckets
	1-Slide Bucket
	1-Twist Bucket

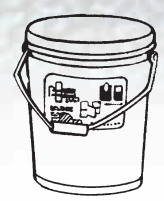

15 Slide pockets per bucket (23 lbs.)
30 Twist pockets per bucket (42 lbs.)
5 Stacking pockets per bucket (17 lbs.)

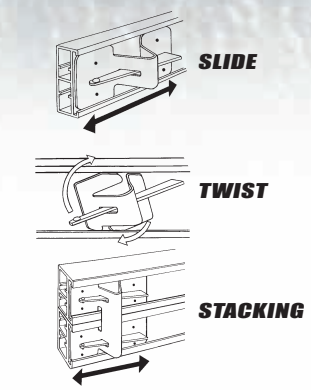

Form To Finish Technology®
www.metalforms.com

Poly Forms

Metal Accessories

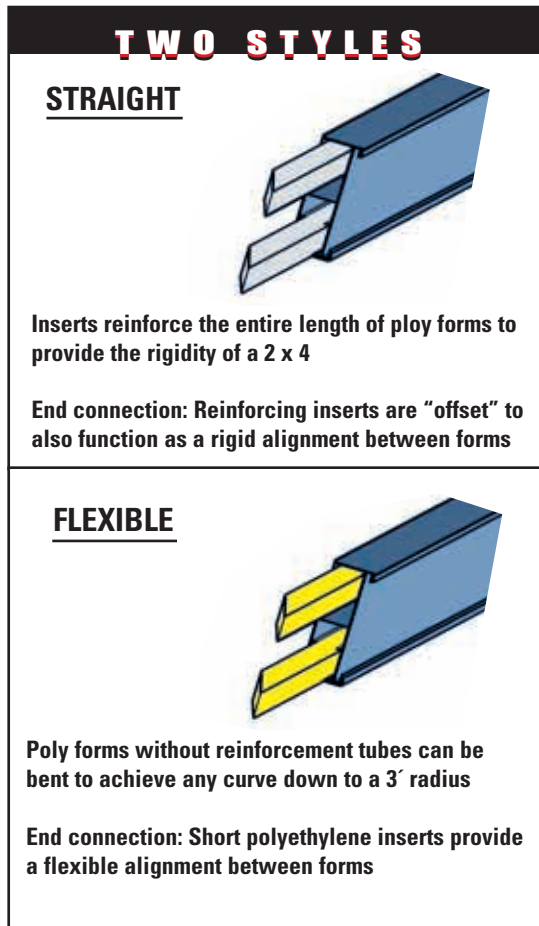
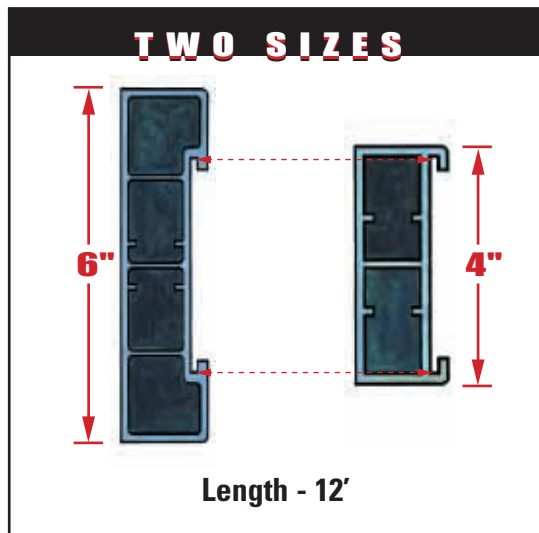

The "SLIDE" pocket is inserted at the end of either the 4" or 6" poly form. Convenient connection to wood with predrilled nail holes.

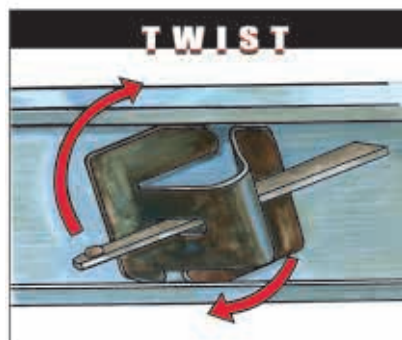

The "TWIST" pocket provides multiple staking options since it can be easily inserted at any location along the length of any form.



The slide-type "STACKING" pocket permits poly forms to be stacked to achieve heights of 8", 10" and 12".



The versatile twist-in "OVERHEAD HANGER" is adjustable for both curb thickness and curb batter (layback).

